



Dr. Bbosa Science

UGANDA NATIONAL EXAMINATION BOARD

PRIMARY LEAVING EXAMINATION

2010

MATHEMATICS

Time allowed: 2hours 15 minutes



Nurture your dreams

digitalteachers.co.ug

Index No:

Index number entry boxes

Candidate's Name.....

Candidate's signature.....

District

Name.....

Read the following instructions carefully

- 1. This paper has two sections A and B.
2. All the working. For both section A and B must be shown in the spaces provided
3. All working must be done using a blue or black ball Point pen or fountain pen Diagram should be drawn in pencil
4. No calculators are allowed in the examination room.
5. Unnecessary change of work may lead to loss of marks
6. Any hand writing that cannot easily be read may lead to loss of marks
7. Do not fill anything in the boxes indicated:
'For examiners'. And those inside the question paper

Table with 3 columns: Qn.No, MARKS, EXR'S NO. and rows for question ranges and a Total row.

SECTION A: (30MARKS)

Questions 1 to 30 carry one mark each

1. Workout: $10 \div 2 = 5$

2. Simplify $2x+3x = 5x$

3. Write in figure: sixty one thousand. : 61,000

4. Given set $A = \{a, b, f, k\}$ and set $B = \{a, c, k\}$ find $n(A \cup B)$.

$$(A \cup B) = \{a, b, c, f, k\}$$

$$n(A \cup B) = 5$$

5. Simplify: $-5 + -2 = -5 - 2 = -7$

6. Write 49 in roman numerals

XLIV

7. Shade $\frac{1}{2}$ of the drawing below

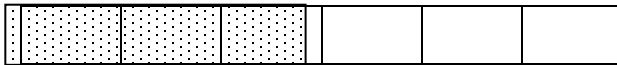

8. Using a pair of compasses, a ruler and a pencil only, bisect the line below.

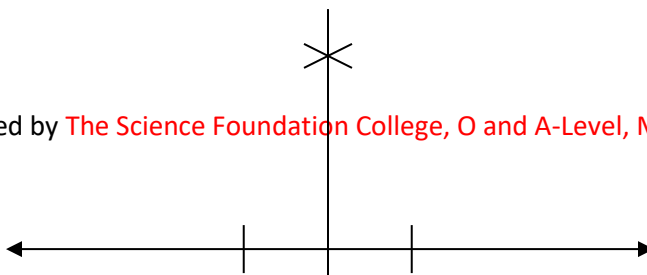

9. What is the value of 5 in the figure 65011?

$$5 \times 1000 = 5000$$

10. Change 2.5 metres into centimeters.

$$1\text{m} = 100\text{cm}$$

$$2.5\text{m} = 2.5 \times 100 \text{ cm} = 250\text{cm}$$

11. Cards labeled 1 to 5 are folded, put in a basket and mixed up. What is the probability of picking a card having a prime number?

Total members are { 1, 2, 3, 4, 5 }

Prime members are { 2, 3, 5 }

$$\text{Probability} = \frac{n\{\text{prime member between 1-5}\}}{n\{\text{members 1-5}\}} = \frac{3}{5}$$

12. Seven children had the following ages: 7, 3, 6, 2, 5, 1 and 4. Find the mean age.

$$\text{Mean or average} = \frac{\text{sum of the number}}{\text{number of item}} = \frac{7 + 3 + 6 + 2 + 5 + 1 + 4}{7} = \frac{28}{7} = 4$$

13. In the triangle below, find the size of angle g in degrees.

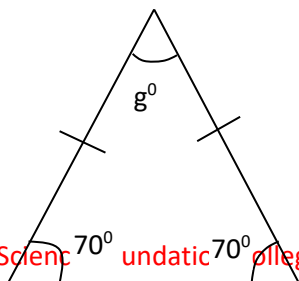

$$70^{\circ} + 70^{\circ} + g^{\circ} = 180^{\circ} (\text{angle sum of a triangle})$$

$$g^{\circ} = 40^{\circ}$$

14. Workout

$$\begin{array}{r} 165 \\ \times 4 \\ \hline 660 \\ \hline \end{array}$$

15. Given that $a = -3$ and $b = 4$, find the value of $2a + 2b$

$$\text{Substitute: } 2 \times -3 + 2 \times 4$$

$$= -6 + 8$$

$$= 2$$

16. Find the next number in the sequence: 23, 19, 16, 14, _____

$$\begin{array}{cccccc} 23, & 19, & 16, & 14, & \underline{13} \\ \underbrace{\quad} & \underbrace{\quad} & \underbrace{\quad} & \underbrace{\quad} & \\ -4 & -3 & -2 & -1 & \end{array}$$

17. A fifty minutes test started at 9.50 a.m. what time did it end?

$$\begin{array}{r} 9:50 \\ + 50 \\ \hline 10:40 \text{ a.m.} \\ \hline \end{array}$$

18. Solve: $4p - 4 = 20$

$$4p - 4 = 20$$

$$4p = 24$$

$$p = 6$$

19. In a line of vehicles, a bus was the 7th from each end of the line. How many vehicles were in the line?

There 13 vehicles

20. In the Venn diagram below, shade the area (YUQ)'

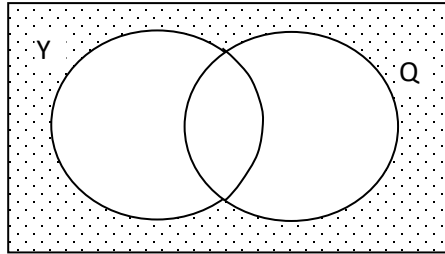

21. Work out: $\frac{5}{12} \div \frac{5}{9}$

$$= \frac{5}{12} \times \frac{9}{5} = \frac{3}{4}$$

22. Change 11_{ten} to base two.

		R
2	11	1
2	5	1
2	2	0
	1	

$$11_{\text{ten}} = 1011_{\text{two}}$$

23. In the graph below, find the co-ordinates of point K.

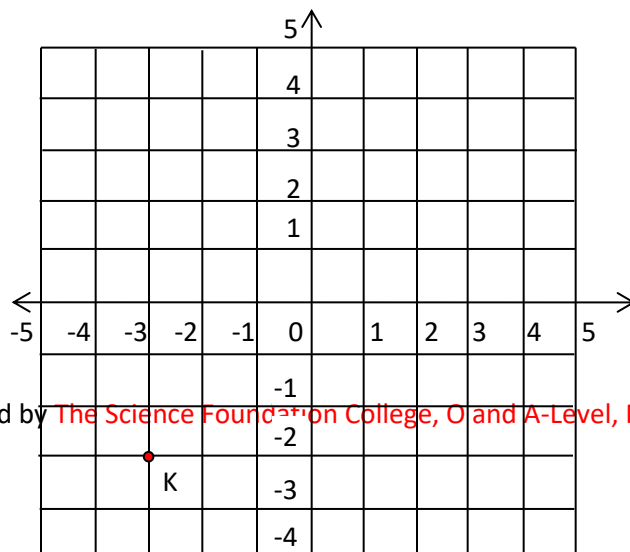

24. A boy ran a distance of 6km in 45 minutes. What was his speed in kilometers per hour?

$$\text{Change 45 minutes to hours} = \frac{45}{60} = \frac{3}{4}$$

$$\text{Speed} = \frac{\text{distance}}{\text{time}} = 6 \div \frac{3}{4} = 6 \times \frac{4}{3} = 8 \text{ km hr}^{-1}$$

25. Arrange the following decimals in order beginning with the smallest 0.11, 0.5 and 0.03.

0.03, 0.11, 0.5

26. How many edges does the below have

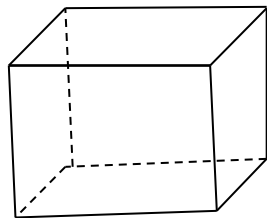

12 edges

27. Work out

$$\begin{array}{r} 6702 \\ -4865 \\ \hline 1837 \end{array}$$

28. Four packets of mango juice cost sh 12,000. What is the cost of seven similar packets?

4 mangoes cost 12,000

7 mangoes cost $\frac{12000 \times 7}{4} = \text{shs. } 21,000$

29. In a P7 class, $\frac{2}{5}$ of the pupils are girls, if there are 150 pupils in the class, find the number of boys.

Fraction of boys = $1 - \frac{2}{5} = \frac{5-2}{5} = \frac{3}{5}$

Number of boys = $\frac{3}{5} \times 150 = 90 \text{ boys}$

30. In the figure below, find the bearing town Z from town W.

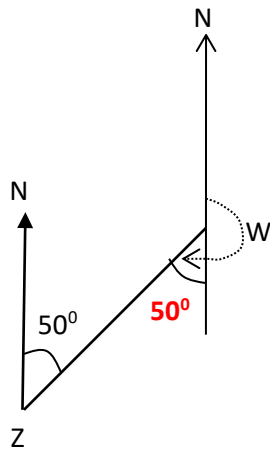

The bearing of Z from W = $180^\circ + 50^\circ$
 $= 230^\circ$

SECTION: (70MARKS)

Mark for each part the question are indicated in the brackets.

31. In a class party of 51 pupils, 28 drank Mirinda (M). 29 drank Pepsi (P), Y drank both Mirinda and Pepsi while 6 did not drink any of the two soda.

(a) Use the information given above to complete the Venn diagram below

(2marks)

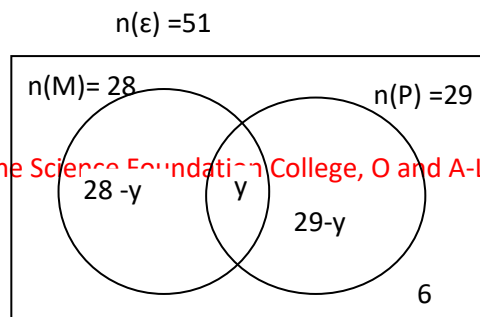

(b) Find the values of y .

$$28 - y + y + 29 - y + 6 = 51$$
$$y = 12$$

(c) Find the number of pupils who drank one type of soda only (2marks)

$$\begin{aligned} \text{The number of pupils that drank one soda} &= (28-y) + (29-y) \\ &= 28 - 12 + 29 - 12 \\ &= 33 \text{ pupils} \end{aligned}$$

32. (a) using a ruler, a pencil and a pair of compasses only construct a rectangle ABCD in which $AB=8\text{cm}$, and $BC=7\text{cm}$ (4marks)

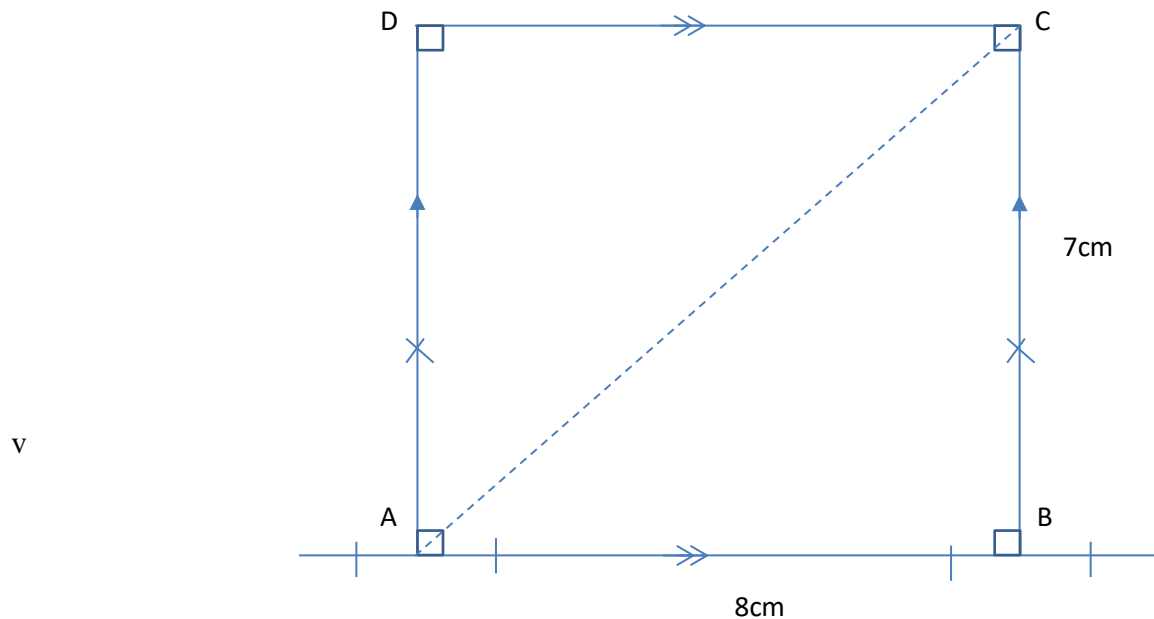

(b) Measure the length of diagonal AC: 10.6cm (1mark)

(c) Measure the angle BAC: 40° (1mark)

33. The table below show the arrival and departure time for a bus that travels from Kampala to Hoima daily.

Town	Arrival time	Departure time
Kampala		7:30 am
Busunju	8:10 am	8:30 am
Bukomero	9:30 am	9:45a.m
Kibogo	10:15a.m	10:40 am
Hoima	11:49 am	

(a) At what time does the bus leave Kampala? (1mark)

At 7:30am

(b) How long does the bus stay at Bukomero? (2marks)

$$\begin{array}{r}
 9: 45 \\
 - 9: 30 \\
 \hline
 15 \text{ minutes} \\
 \hline
 \end{array}$$

(c) How long does the bus take to travel from Bukomero to Kiboga? (2marks)

$$\begin{array}{r}
 10: 15 \\
 - 9: 45 \\
 \hline
 30 \text{ minutes} \\
 \hline
 \end{array}$$

(d) Find the total time taken by the bus to travel from Kampala to Hoima (2marks)

$$\begin{array}{r}
 11: 40 \\
 - 7: 30 \\
 \hline
 4: 10 \quad 4\text{hour and } 10\text{minutes} \\
 \hline
 \end{array}$$

34. (a) solve $2m+3=18-m$ (3marks)

Collect like term to one side

$$2m + m = 18 - 3$$

$$3m = 15$$

$$m = 5$$

(b). Solve: $2(3x-1) - 4(x-1) = 4$

(3marks)

$$6x - 2 - 4x + 4 = 4$$

$$2x = 2$$

$$x = 1$$

35. In the diagram below, OP is parallel to QR, HKL is triangle, angle HLR = 110° and angle SHP = 50°

Study it and answer the questions that follow.

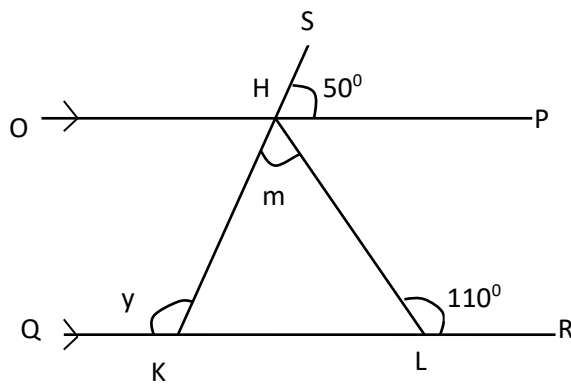

Find the size of

(a) Angle y:

(2marks)

angle SKI = angle SHP = 50° (corresponding angle)

Angle y + angle SKI = 180° (angle sum on a straight line)

$$y + 50^\circ = 180^\circ$$

$$y = 130^\circ$$

(b) angle M

(3mark)

angle HIK + $110^\circ = 180^\circ$ (angle sum on a straight line)

$$\text{angle HIK} = 70^\circ$$

Angle HIK + angle HKI + m = 180° (angle sum of triangle)

$$70^0 + 50^0 + m = 180^0$$

$$m = 60^0$$

36. (a) Find the number which has been expanded below.

$$(1 \times 10^4) + (3 \times 10^2) + (6 \times 10^0) \quad (3 \text{ marks})$$

$$= 10000 + 300 + 6$$

$$= 10,306$$

(b) Change 1011_{two} to base ten (2 marks)

$$(1 \times 2^3 + 0 \times 2^2 + 1 \times 2^1 + 1 \times 2^0) = (8 + 0 + 2 + 1) = 11$$

(c) find the value of x; $3+3= x$ (finite 4). (2 marks)

$$6 = x \text{ (infinite 4)}$$

$$\frac{6}{4} = 1r2$$

$$x = 2$$

37. Find the area of the shaded part in the diagram below.

(Take π as $\frac{22}{7}$).

(6 marks)

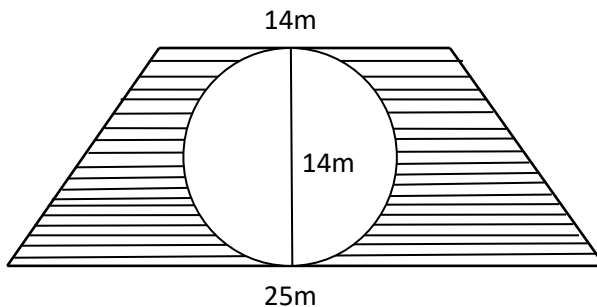

$$\text{Area of circle} = \pi r^2 = \frac{22}{7} \times \frac{14}{2} \times \frac{14}{2} = 154 \text{ cm}^2$$

$$\text{Area of trapezium} = \frac{1}{2} h(a + b) = \frac{1}{2} \times 14 (14 + 25) = 273 \text{ cm}^2$$

$$\text{Shaded part} = 273 - 154 = 119 \text{ cm}^2.$$

38. the mean of the score 8, 9, 6, 4 and x is 6

(a) Find the value of x

(3marks)

$$\text{mean} = \frac{\text{sum}}{\text{number of item}}$$

$$\frac{8+9+6+4+x}{5} = 6$$

$$27 + x = 30$$

$$x = 3$$

(b) What is the median score?

(1mark)

Median = middle score in order of size

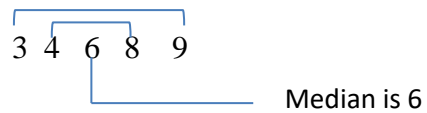

(c) Find the probability that score picked at random below the mean

(2marks)

$$\text{Mean} = 6$$

$$\text{Below mean} = \{3,4\}$$

$$\text{Probability} = \frac{2}{5}$$

39. Makeba's car uses 8litrer of petrol for every 50km.

(a) how much petrol does he need for a journey of 325km?

(2marks)

50km take 8 liters

$$325 \text{ km take } \frac{8 \times 325}{50} = 52 \text{ litres}$$

\therefore 325km require 52 litres

(c) If litre of petrol costs shs. 2,900, how much money will he spent on petrol needed to run the car for $1\frac{1}{2}$ hour at a speed of 50 km per hour?

$$\text{Distance} = \text{speed} \times \text{time} = 50 \times 1\frac{1}{2} = 75\text{km}$$

Total fuel required to run 75km

50km require 8litres

$$75\text{km require } \frac{8 \times 75}{50} = 12\text{litres}$$

$$\text{Cost of 12 litres} = 12 \times 2900 = \text{shs. } 34800$$

40. The graph below shows the change in body temperature of a patient in a hospital recorded every two hours in a day.

Use it to answer the question that follow.

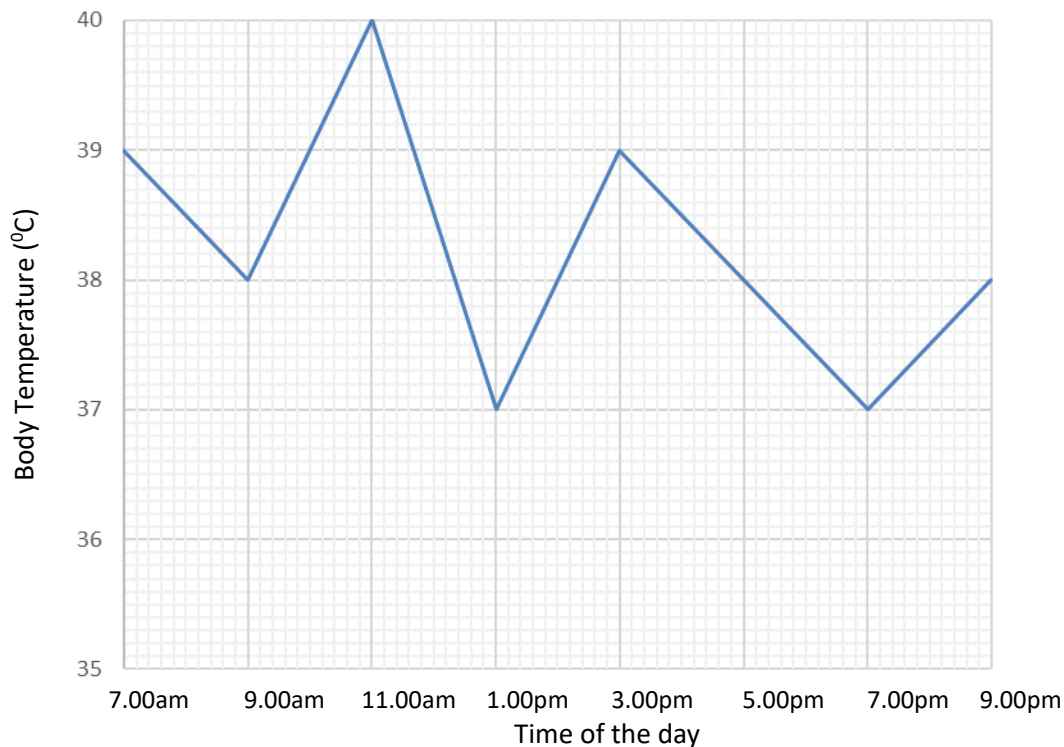

(a) What was the highest temperature recorded? 40°C

(1mark)

(b) Find the range in the recorded body temperature. (1mark)

$$\begin{aligned} \text{Range is highest} - \text{lowest} \\ = 40 - 37 = 3^{\circ}\text{C} \end{aligned}$$

(c) Work out the average body temperature of the patient from 3.00pm to 9.00m (3marks)

$$\text{mean} = \frac{\text{sum}}{\text{number of item}} = \frac{39+38+37+38}{4} = 38^{\circ}$$

41. A man spends $\frac{1}{3}$ his salary on food, $\frac{1}{9}$ on clothing on medical, $\frac{1}{6}$ on house rent and bank the rest which is shs. 35,000.

(a) What fraction of his salary does he bank? (3marks)

$$\text{Food} \quad \frac{1}{3}$$

$$\text{Clothing} \quad \frac{1}{9}$$

$$\text{Medical} \quad \frac{1}{6}$$

$$\text{Rent} \quad \frac{1}{18}$$

$$\text{Used fraction} = \frac{1}{3} + \frac{1}{9} + \frac{1}{6} + \frac{1}{18} = \frac{12}{18} = \frac{2}{3}$$

$$\text{Banked fraction} = 1 - \frac{2}{3} = \frac{1}{3}$$

(b) How much money he earns as salary? (2marks)

Let the total salary be Q

$$\frac{1}{3} \text{ of } Q = 35000$$

$$Q = 105,000$$

42. Simplify

(a) $n^2 \times n = n^3$

(1mark)

(b) $m^6 \div m^3 = m^{(6-3)} = m^3$

(1mark)

(c) $\frac{a^2 \times a^5}{a^3} = \frac{a^{2+5}}{a^3} = a^{7-3} = a^4$

(2marks)

END